



## OVERHEAD FIRE DOOR Type: **MARC-O EI60**

*THANK YOU FOR YOUR TRUST AND FOR PURCHASING THE PRODUCTS FROM „MAŁKOWSKI-MARTECH” S.A.*



## CONTENTS

<b>1. INTRODUCTION</b>	3
<b>2. APPLICATION SCOPE AND PREREQUISITES</b>	4
2.1 INTENDED USE	4
2.2 NON-INTENDED USE	4
2.3 OHS RECOMMENDATIONS	6
2.4 SERVICE PERSONNEL REQUIREMENTS	6
<b>3. PACKAGING, STORAGE, AND TRANSPORT</b>	6
<b>4. ASSEMBLY AND INSTALLATION</b>	7
4.1 MECHANICAL INSTALLATION	7
4.2 ELECTRICAL INSTALLATION	7
<b>5. OPERATING PRINCIPLE OF THE ELECTRICAL ACCESSORIES KIT</b>	8
<b>6. TECHNICAL SPECIFICATIONS</b>	8
6.1 DOOR LEAF	11
6.2 WALL STOP	13
6.3 DOOR GUIDE RAIL ASSEMBLY	14
6.4 CABLE/BELT PULLEY ASSEMBLY	16
6.5 COUNTERWEIGHT ASSEMBLY	17
6.6 E-MAG HOLDER ASSEMBLY	18
6.7 GUIDE RAIL FASCIA	20
6.8 MARC-EH ELECTRICAL ACCESSORIES KIT	21
6.9 MARC-VIC 040x ELECTRICAL ACCESSORIES KIT	22
6.10 MARC-VIC 010x ELECTRICAL ACCESSORIES KIT	24
6.11 MARC-VIC 012x ELECTRICAL ACCESSORIES KIT	26
<b>7. TROUBLESHOOTING</b>	27
<b>8. INSPECTION, MAINTENANCE, AND REPAIRS</b>	27
8.1 INSPECTION & MAINTENANCE SCHEDULE	27
8.2 OPERATOR'S INSPECTIONS	29
8.3 SERVICE INSPECTIONS & MAINTENANCE	29
8.4 CLEANING & LUBRICATION	30
8.5 REPLACEMENT PARTS	30
<b>9. DISPOSAL</b>	30
9.1 CHEMICAL NOTICE	30
<b>10. IDENTIFICATION</b>	31
<b>11. APPENDICES</b>	32



<b>MAŁKOWSKI MARTECH</b> Czołowo, ul. Leśna 57, 62-035 Kórnik phone: +48 61 222 75 00 fax: +48 61 222 75 01 email: biuro@malkowski.pl, www.malkowski.pl	<b>OVERHEAD FIRE DOOR type: MARC-O EI60</b>	Ref. no.: <b>ISOIK_O-1</b>
	<b>INSTRUCTIONS FOR USE, OPERATION AND MAINTENANCE</b>	Revision: <b>03/2021</b>

## 1. INTRODUCTION

This Instructions Manual for Type MARC-O EI60 overhead fire door (henceforth the 'fire door' or the 'product') features the data and guidance for the fire door owner/user required to understand the operating principle, application, operation, and maintenance of the fire door.

To ensure long-term, safe use of the fire door, the user and operating personnel shall fully understand and comply with this Manual.

The use of the fire door, including its operation, maintenance, servicing, periodic inspection, parts replacement, and repairs shall conform to this Manual.

Keep the Manual and other technical documentation appended to it safe and available to the operators and service technicians.

We reserve the right to continuous verification of the Manual contents and their adaptation to the state of the art. We hope the user understands that the Manual contents can be modified without prior notice. Some of the figures and narrative of this Manual may vary from the actual product, and if so, it is due to continuous improvement necessary due to changes in regulations of law and similar reasons; these variations do not affect the recommendations for use applicable to the product.

If this Manual is lost or damaged, contact our Customer Service and order the same version of the document.

### CAUTION!

**Failure in compliance with the recommendations and guidelines contained in this Manual will release the manufacturer from all liability and warranty obligations.**

**The servicing intended to be done by the service technicians and the user is specified further in this Manual. Only the manufacturer's authorized service may attempt assembly, installation, adjustment, parts replacement, repairs, and troubleshooting of this product.**

**This Manual applies to the standard accessories of the overhead fire door; the application of optional accessories, if any, is specified in the sales contract for the product.**

The overhead fire door shall be used according to the engineering design developed for the intended installation location, and with consideration of the following:

- The prevailing construction and engineering standards and regulations, of which the particular ones apply:
  - a) Regulation of the European Parliament and of the Council (EU) No. 305/2011 of 9 March 2011 laying down harmonised conditions for the marketing of construction products and repealing Council Directive 89/106/EEC (OJ EU L88 04/04/2011, as amended);
  - b) Polish Construction Products Act of 16 April 2004 (Dz.U. 2019.266.730);
  - c) Polish Building Code Act of 7 July 1994 (Dz.U. 2019.1186, as amended);
  - d) Polish Act of 13 April 2016 on the Conformity System and Market Surveillance (Dz.U. 2019.544);
  - e) Polish Fire Protection Act of 24 August 1991 (Dz.U. 2019.1372/1518/1593);
  - f) Polish Regulation of the Minister of Infrastructure and Construction dated 17 November 2016 and concerning the Practice of Declaration of Performance for and Construction Mark Labelling of Construction Products (Dz.U. 2016.1966);
  - g) Polish Regulation of the Minister of the Interior and Administration dated 7 June 2010 and concerning the Fire Protection of Buildings, Structures, and Land (Dz.U. 2010.109.719, as amended);
  - h) Polish Regulation of the Minister of Infrastructure dated 12 April 2002 and concerning the Technical Requirements for Buildings and Locations Thereof (Dz.U. 2015.1422, as amended);
  - i) EN 16034:2014-11 (Harmonised standard), Pedestrian doorsets, industrial, commercial, garage doors and openable windows – Product standard, performance characteristics – Fire resisting and/or smoke control characteristics;
  - j) PN-EN 13501-2:2016-07, Fire classification of construction products and building elements – Part 2:



- Classification using data from fire resistance tests, excluding ventilation services;
- k) EN 13241+A2:2016-10 (Harmonised standard), Industrial, commercial, garage doors and gates – Product standard, performance characteristics;
  - l) PN-EN 12635+A1:2010, Industrial, commercial and garage doors and gates – Installation and use;
  - m) PN-EN 12424:2002 Industrial, commercial and garage doors and gates – Resistance to wind load – Classification;
- The Declaration of Performance;
  - These Instructions for Use, Operation and Maintenance.

Pursuant to the EN standard (i) and the Regulation (f), the fire door is a construction product eligible for System 1 of Assessment and Verification of Constancy of Performance.

Based on the Regulation (a), the manufacturer who markets a construction product is required to issue its Declaration of Performance (DoP) and apply a legible CE marking label to the product.

### **CAUTION!**

**A copy of the Declaration of Performance and the Warranty Certificate are provided by the manufacturer to the user after the acceptance of the installation/assembly of the fire door, in accordance with the sales contract (and/or the quotation).**

**A copy of the Declaration of Performance and the Warranty Certificate for the fire door is an integral part of this Manual and shown as its Appendices, ref. Section 11 APPENDICES.**

**The CE marking of the fire door is placed on its nameplate, ref. Section 10 IDENTIFICATION.**

**The valid list of authorized providers of product installation, service inspections, and maintenance (complete with assessment and certification of proper performance of these services) is available on the official website of the fire door manufacturer ([www.malkowski.pl](http://www.malkowski.pl)).**

## **2. APPLICATION SCOPE AND PREREQUISITES**

### **2.1 INTENDED USE**

Type MARC-O EI60 overhead fire door is a vertical, moving fire partition intended as the closure of a passageway between fire partitioned zones inside of industrial buildings, warehouse rooms, technical access floors in office buildings, hospitals, and other public buildings.

The standard version of type MARC-O overhead fire door is manufactured in the declared use category C0 (with the number of cycles 1 to 499 per EN 16034:2014-11) and wind load resistance class 1 (per PN-EN 12424:2002).

On special request, type MARC-O EI60 overhead fire door can be manufactured in the declared use category **1** (500 to 9,999 cycles) or **2** (10,000 to 49,999 cycles) or **3** (50,000 to 99,999 cycles) or **4** (100,000 to 199,999 cycles) and wind load resistance class **2, 3** or **4**.

### **2.2 NON-INTENDED USE**

Type MARC-O EI60 overhead fire door is not intended for the following applications:

- In Ex-zones (explosion hazard areas), unless qualified as intended for the application following suitable modifications by the manufacturer;
- In environmental conditions with presence of salinity, salts, acids, alkali, and/or other aggressive chemical (including cement and lime) which trigger corrosion (the maximum permitted relative humidity is 80% for this product);
- When exposed to strong electromagnetic fields (> 0.1 T);
- In areas with wind exposure with a force higher than the wind load resistance class stated on the nameplate and a copy of the Declaration of Performance.

### **CAUTION!**

**The PN-EN 12424:2002 wind load resistance has been determined for the closed door. Operation of the**





<b>MAŁKOWSKI MARTECH</b> Czołowo, ul. Leśna 57, 62-035 Kórnik phone: +48 61 222 75 00 fax: +48 61 222 75 01 email: biuro@malkowski.pl, www.malkowski.pl	<b>OVERHEAD FIRE DOOR type: MARC–O EI60</b>	Ref. no.: <b>ISOIK_O-1</b>
	<b>INSTRUCTIONS FOR USE, OPERATION AND MAINTENANCE</b>	Revision: <b>03/2021</b>

**door in high winds can be hazardous!**

Never attempt to:

- have the fire door assembled by a contractor who has not been authorized by the product manufacturer;
- repair, troubleshoot, improve, alter, modify, or replace or retrofit components or parts outside of the specification limits shown in this Manual and/or without a prior written authorization from the fire door manufacturer (ref. the manufacturer’s authorization matrix in Section 6 TECHNICAL SPECIFICATION);
- install any parts or components which are non-genuine or non-original or not specified and/or authorized by the fire door manufacturer;
- operate the fire door which is defective, out of order or partially or wholly incompatible with the specified properties or intended use (due to damage from fire, a building collapse, etc.);
- operate the fire door without the required operator’s inspections, periodic service inspections, and/or maintenance done as specified in this Manual (ref. Section 8 INSPECTION, MAINTENANCE, AND REPAIRS) or as specified in the custom provision of the sales contract concluded between the user and the manufacturer of the fire door;
- operate the fire door with mechanical damage or other defects caused by misuse, especially if it has been stopped in an emergency and the reason has not been cleared;
- operate the fire door if it or any of its components have been found to work abnormally and the relevant supervisor, maintenance team and the manufacturer’s technical service have not been notified;
- operate the fire door with its nameplate defaced or removed;
- service or repair the fire door when its components are in motion;
- walk, run, or drive through the fire door in motion;
- wash or clean the fire door with formulas that are corrosive and/or based on any acid or solvent, or pressure clean with any liquid (see Section 8.4 CLEANING AND LUBRICATION).

Failure to comply with the foregoing restrictions will have the user lose all liabilities and warranty obligations of the manufacturer towards the former, including loss of the declared fire resistance and the DoP issued by the manufacturer.

**CAUTION!**

The manufacturer shall be released from their liability and warranty obligations:

- if the product has been installed by a contractor not authorised by the manufacturer;
- for all natural, whether partial or complete, wear and tear resulting from the characteristics or intended use of the fire door (which includes exposure to fire);
- if the user or any third party alters, modifies, or replaces components or structural features of the fire door without coordination and prior written authorisation of the manufacturer;
- for misuse or failure in routine maintenance of the fire door or its components as required by this Manual;
- for failure in the periodic inspections required in this Manual or any binding, custom agreement with the manufacturer or its authorized technical service, if the failure has caused damage and other defects (including the defacement or removal of the nameplate).

In the foregoing circumstances the manufacturer does not warrant that the declared fire resistance of the door will be maintained any longer.

To ensure reliable operation and compliance with the warranty terms and conditions, please contact MAŁKOWSKI-MARTECH S.A. or its commercial partner for product training. The purpose of the training is to provide the necessary information about proper use and, among others, the requirements for operating personnel.



<b>MAŁKOWSKI MARTECH</b> Czołowo, ul. Leśna 57, 62-035 Kórnik phone: +48 61 222 75 00 fax: +48 61 222 75 01 email: biuro@malkowski.pl, www.malkowski.pl	<b>OVERHEAD FIRE DOOR type: MARC-O EI60</b>	Ref. no.: <b>ISOIK_O-1</b>
	<b>INSTRUCTIONS FOR USE, OPERATION AND MAINTENANCE</b>	Revision: <b>03/2021</b>

## 2.3 OHS RECOMMENDATIONS

The operation of the fire door requires compliance with the prevailing general occupational health and safety laws, including legal prerequisites of fire protection and timely inspections, servicing, maintenance, parts replacement, and repairs which are specified in the requirements. Do not operate the fire door if it has been stopped in an emergency until the root cause is cleared.

Follow the prevailing regulations of law for waste generation control and proper disposal during all work on the fire door. Special caution is required that during cleaning/washing, maintenance, replacement of parts or repairs of the fire door no harmful substances are released into the soil or sewers, like lubricants, solvent-borne cleaning agents, etc. These substances must be collected, contained and shipped for legal disposal in suitable containers.

## 2.4 SERVICE PERSONNEL REQUIREMENTS

The servicing of the fire door requires no professional license. The fire door shall be operated and serviced by an operator (e.g. a maintenance technician) designated by the fire door user. The designated operator requires operating training from the fire door manufacturer's representative or the manufacturer's authorized installation contractor; once completed, the operating training must be certified as such in writing.

The user shall ensure that the operating personnel is and remains trained in occupational health and safety, including the possible risks of this product, the job safety instructions, this Manual, and all instructions attached to this document.

## 3. PACKAGING, STORAGE, AND TRANSPORT

Depending on the sales contract/quotation provisions agreed to with the manufacturer, the fire door can be collected from the manufacturer's warehouse or shipped and delivered by the manufacturer to the installation side against a written proof of acceptance of the product quantity and quality on the Goods Issue Note.

The fire door is delivered in assemblies and components to be assembled and installed at the user's site. Each assembly and component is separately protected against mechanical damage for the duration of shipping as follows:

- the door leaf panes are stacked on a pallet no smaller than the single panel dimensions when laid flat, with waste wool or expanded polystyrene spacers between the panels, with the palletized stack wrapped in film and bound with straps over square timber pieces for protection of the product's edges;
- the trim pieces are placed on spacers of mineral wool or expanded polystyrene either on the door leaf panel pallet or on a separate pallet;
- small accessory items, like fasteners, etc. are packed in a separate cardboard box;
- each delivery packaging is labelled with the packing list of the assemblies and components, showing the customer's purchase order, the assembly number, the fire door type, and the DoP reference number.

Transport, storage, and assembly/installation of the fire door are regulated as follows:

- The assemblies, components, and single parts of the fire door must be properly secured in transport (with lashing, straps, spacers, etc.);
- Following the unloading from delivery and for the duration of storage, store all parts of the fire door in a sheltered room, away from sources of damage, dirt, and the elements (like snow and rain);
- Do not step, walk, or drive over any assembly, component, or part of the fire door; do not place any loads, tools, or any chemicals on these items; do not lead on these items; do not attempt anything unspecified here which might contribute to damage and reduction of value/quality of the fire door items.



<b>MAŁKOWSKI MARTECH</b> Czołowo, ul. Leśna 57, 62-035 Kórnik phone: +48 61 222 75 00 fax: +48 61 222 75 01 email: biuro@malkowski.pl, www.malkowski.pl	<b>OVERHEAD FIRE DOOR type: MARC-O EI60</b>	Ref. no.: <b>ISOIK_O-1</b>
	<b>INSTRUCTIONS FOR USE, OPERATION AND MAINTENANCE</b>	Revision: <b>03/2021</b>

#### 4. ASSEMBLY AND INSTALLATION

The electrical and mechanical installation and assembly of the fire door shall only be done by trained personnel of the manufacturer or its authorized installation contractors.

Fire door pre-installation/assembly procedure:

- Before attempting the work, inspect all delivery items for incorrect quantity and damage during transport or storage;
- Verify conformity of the installation conditions against the purchase order / sales contract drawing;
- All connections and joints must be carefully made and assembled and re-checked for proper tightening and fit.

Install the fire door in compliance with the installation instructions (ref. Section 11 APPENDICES), and follow with the installation work inspection and functional testing.

The acceptance of the installed fire door is to be done in witness of the buyer's authorized and the manufacturer's authorized representatives (it can be witnessed on behalf of the manufacturer, by the authorized installation contractor) who will certify the acceptance in the Periodic Inspection and Maintenance Log (appended to this Manual) or in a separate installation acceptance certificate.

##### 4.1 MECHANICAL INSTALLATION

The assembly/installation of the mechanical components of the fire door shall proceed in compliance with the installation instructions (ref. Section 11 APPENDICES), which are dedicated engineering documents intended only for the installation contractor's foremen who hold the relevant installation certificates issued by the fire door manufacturer.

##### CAUTION!

**For proper handling, lifting, and fastening of the fire door structure, ensure proper OHS conditions and the work equipment required for the tasks, like ladders of suitable height, fall arrest harnesses, lifelines and other gear, e.g. slings, lifting beams, a hoist, or a MEWP with a lift capacity and outreach sufficient for the weight and installation height of the product's structure.**

**The sales contract specifies the party required to secure the work equipment for the assembly, installation, and periodic inspections/maintenance processes.**

##### 4.2 ELECTRICAL INSTALLATION

The configuration of the electrical accessories for the fire door depends on the purchase order specifications and their installation must conform to the engineering documentation (for the installation contractor) appended to this Manual.

The electrical wiring diagram is shown inside of the control panel cover and in the electrical accessories installation manual appended to this Manual (ref. Section 11 APPENDICES).

##### CAUTION!

**The fire door user shall prepare the electrical power connection at the fire door installation site for this product. The electrical power connection shall have compatible electrical and protection ratings to permit wiring to the fire door, its functional testing, and normal operation.**

**The electrical power connection must be wired to the fire door electrical accessories, tested, and repaired whenever it fails by a suitably licensed professional electrician only.**



## 5. OPERATING PRINCIPLE OF THE ELECTRICAL ACCESSORIES KIT

The primary function of the electrical accessories (ref. Sections 6.7 to 6.10 ELECTRICAL ACCESSORIES KIT) is to automatically operate the fire door to close whenever a fire hazard is detected and signalled. A detailed description of the structure, installation and operation of the fire alarm and detection accessories delivered with the fire door is included in the electrical accessories installation manual appended to this Manual.

The fire door leaf is retained within the guide rail assembly and held open with an e-mag holder or an electric motor wired to a fire-safety power supply, which in turn can be factory-provided with a fire alarm control panel or wired directly to the on-site fire alarm system.

If smoke / heat sensors detect a hazard of fire, the fire alarm control panel or the fire-safety power supply is triggered by the fire detection signal to:

- isolate the e-mag holder from live voltage, which releases the fire door to close by its weight, and the weight difference of the door leaf and its counterweight help maintain the maximum permissible closing speed;

or

- the fire-safety power supply energizes the fire door motor which operates the leaf to close (optional).

The door leaf can be alternatively released manually, with a dedicated emergency close button wired to the control panel.

When the reason for the fire alarm signal is clear, the control panel reverts to normal operation; now, the fire door leaf must be manually operated to open until the e-mag holder contacts are made OR automatically operated with the electric motor to the fully open position. The door leaf stops in the fully open position triggered by the limit switches integrated with the drive unit.

## 6. TECHNICAL SPECIFICATIONS

Specification	Value	Notes
Fire resistance class	EI <sub>2</sub> 60	-
Closing speed	< 0.15 m/s	-
Operation (manual / powered)	-	Gravity-assisted closing through the door leaf and counterweight mass differential. Manual or powered opening.
Leaf colour	Any in the RAL palette On request	Standard colours: RAL 9002, 9010, 7035
Fascia colour		





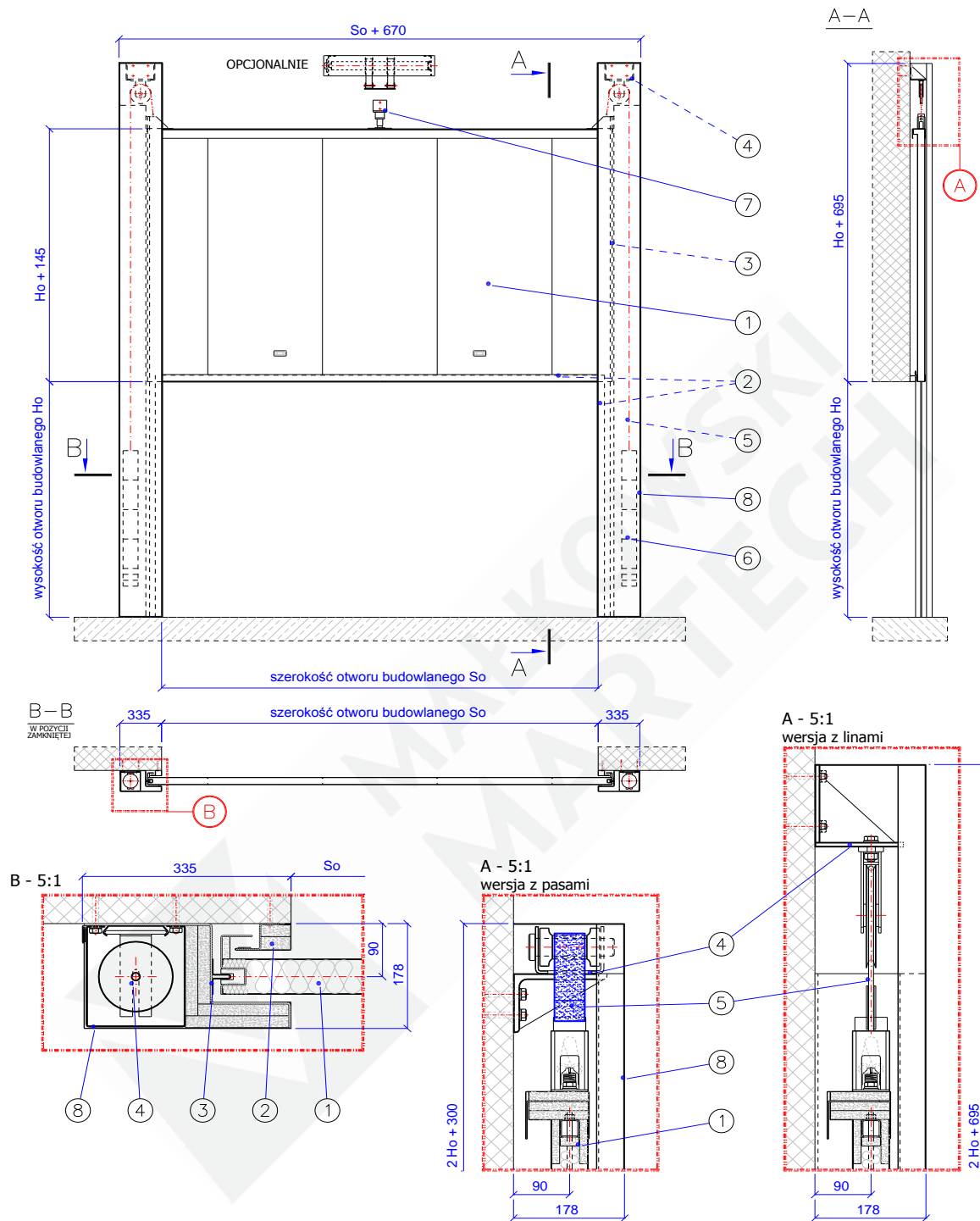

opcjonalnie	Optional
wysokość otworu budowlanego Ho	Clear opening height Ho
szerokość otworu budowlanego So	Clear opening width So
wersja z pasami	Carrier belt version
wersja z liniami	Carrier cable version

**Fig. 1 – Type MARC-R EI60 overhead fire door**

1 – Door leaf; 2 – Wall stop; 3 – Guide rail assembly; 4 – Cable/belt transmission assembly;  
 5 – Carrier cable/belt; 6 – Counterweight assembly; 7 – E-mag holder assembly; 8 – Guide rail post fascia



<b>MAŁKOWSKI MARTECH</b> Czołowo, ul. Leśna 57, 62-035 Kórnik phone: +48 61 222 75 00 fax: +48 61 222 75 01 email: biuro@malkowski.pl, www.malkowski.pl	<b>OVERHEAD FIRE DOOR type: MARC-O EI60</b>	Ref. no.: <b>ISOIK_O-1</b>
	<b>INSTRUCTIONS FOR USE, OPERATION AND MAINTENANCE</b>	Revision: <b>03/2021</b>

### List of components for type MARC-R EI60 overhead fire door

#	Designation	Quantity	Drawing no./ Part no. / Standard
1	Door leaf	1	2 – MARC-O60-01.01.00
2	Wall stop	3	3 – MARC-O60-01.02.00
3	Door guide rail assembly	2	4 – MARC-O60-01.03.00
4	Cable/belt pulley assembly	2	5 – MARC-O60-01.04.00
5	Carrier cable/belt	2	∅6(8), 18x7+FC PN 12385-1, -4 50x4 mm, PN 12195-2
6	Counterweight assembly	2	6 – MARC-O60-01.05.00
7	E-mag holder assembly / VIC drive unit*	1	7 – MARC-O60-01.06.00, * – Depends on the PO specifications.
8	Door guide rail fascia	2	8 – MARC-O60-01.07.00

### LIST OF ANCHORING FASTENERS FOR GUIDE RAIL PROFILES AND CABLE/BELT ASSEMBLIES

NOTE: 1. The standard set of fasteners supplied with the door includes the hardware for installation on concrete (C20/25) and reinforced concrete walls.

2. It is possible to use different fasteners provided if they are marketed with the CE marking or the Polish Construction Mark "B" and have the same or better strength and the same intended use.

#	Anchoring fasteners	Notes
<b>A. REGULAR/PRESTRESSED CONCETE HOLLOW CORE SLABS</b>		
A.1	Hollow core slab anchor Fischer FHY; Hilti HKH	- the size and type are specified for the transmitted loads;
A.2	Sleeved anchor e.g. Fischer EA II; Hilti HKD	
<b>B. WALLS, FLOORS, AND BEAMS OF SOLID/RF CONCRETE</b>		
B.1	Bolt anchor e.g. MKT BZ; Fischer FAZ II; Hilti HST3	- the size and anchoring depth are specified for the transmitted loads;
B.2	Threaded anchor e.g. Fischer FBS II; Hilti HUS HR/CR	
B.3	Chemical anchoring with threaded bars e.g. MKT VM Multi-plus; Fischer FIS SB	- Min. bar size M8 (DIN 976), min. strength class 8.8 (PN-EN ISO 898-1)
<b>C. MASONRY WALLS OF CELLULAR CONCRETE UNITS (e.g. Ytong, Solbet, or Termalica)</b>		
C.1	Chemical anchoring with threaded bars e.g. MKT VM Multi-plus; Fischer FIS V/FIS P	- Min. bar size M8 (DIN 976), min. strength class 8.8 (PN-EN ISO 898-1)
C.2	Through-and-through fastening with threaded bars	- DIN 976 bar; the size is specified for the transmitted loads; min. strength class 8.8 (PN-EN ISO 898-1); - PN-EN ISO 4032 nut, min. strength class 8; - PN-EN ISO 7093 wide washer 200 HV;
<b>D. SOLID MASONRY WALLS (e.g. concrete units, sand lime blocks, solid bricks) OR HOLLOW MASONRY WALLS (e.g. slotted hollow bricks, round hollow core bricks, Porotherm)</b>		
D.1	Chemical anchoring with threaded bars e.g. MKT VM Multi-plus; Fischer FIS V/FIS P	- Min. bar size M8 (DIN 976), min. strength class 8.8 (PN-EN ISO 898-1)
D.2	Through-and-through fastening with threaded bars	- Ref. C.2 – the washers need to be replaces; - PN-EN ISO 4079 washer, 200 HV;
<b>E. FIRE-PROOFED STEEL STRUCTURES AND FIRE STUD WALLS <sup>1)</sup></b>		



<b>MAŁKOWSKI MARTECH</b> Czołowo, ul. Leśna 57, 62-035 Kórnik phone: +48 61 222 75 00 fax: +48 61 222 75 01 email: biuro@malkowski.pl, www.malkowski.pl	<b>OVERHEAD FIRE DOOR type: MARC-O EI60</b>	Ref. no.: <b>ISOIK_O-1</b>
	<b>INSTRUCTIONS FOR USE, OPERATION AND MAINTENANCE</b>	Revision: <b>03/2021</b>

<b>E.1</b>	Threaded fastening	- PN-EN ISO 4014 / 4017 bolt; the size is specified for the transferred loads; min. strength class 8.8 (PN-EN ISO 898-1); - PN-EN ISO 4079 washer, 200 HV; - PN-EN ISO 4032 nut, min. strength class 8;
------------	--------------------	---------------------------------------------------------------------------------------------------------------------------------------------------------------------------------------------------------------

1) – The inner steel profiles must withstand the static and dynamic loads of the fire door installation and operation.

## LIST OF ANCHORING FASTENERS FOR WALL STOPS AND FASCIAS <sup>2)</sup>

F. RF WALLS, CELLULAR CONCRETE MASONRY WALLS, AND HOLLOW OR SOLID MASONRY WALLS		
<b>F.1</b>	Steel wall plug (frame anchor)	- M8; M10; - Min. length 72 mm;
<b>F.2</b>	Plastic frame anchor plug, Hilti HRD-CR	- Size 8; 10, - Min. length 60 mm;
<b>F.3</b>	Steel sheet screws e.g. Hilti S-MD; Stalco WS / FD / FM; Etanco GT	- min. St 4.8 x 25 (DIN 7504); - The size is specified for the transferred loads and thickness of the mating component walls

2) – All hardware listed in B, C, D, and E may also be used.

### 6.1 DOOR LEAF

The door leaf is the primary component of the overhead fire door. When closed, it forms a sealed, integral partition with the fire resistance rating of EI60.

The door leaf is 60 mm thick and comprises panels which can be 400 to 1200 mm wide, two side profiles, the bottom profile, bracing hardware, and cladding of galvanized sheet steel.

Each door leaf panel has a core of mineral wool, P/N PRO<sub>MM</sub>18.

On both sides of the door leaf, the mineral wool core panels are bonded with adhesive, P/N PRO<sub>MM</sub>2, PRO<sub>MM</sub>12, or O-PA to vertically oriented galvanized steel sheets, PN-EN 10346:2015-09 grade DX51D+Z275, and 0.5 to 0.7 mm thick. Inside of each panel is a dia. 8.0 mm vertical bar of PN-EN 10025-2:2019-11 grade S235JR steel, both ends of which are tapped and ties the top horizontal bracing profile to the bottom profile. The bottom hat profile is formed from 2.0 to 3.0 mm thick steel sheet, PN-EN 10346:2015-09 grade DX51D+Z275. The bottom profile and the top horizontal bracing profile are tied on both ends by upright side profiles. The upright side profiles are hat profiles formed from 2.0 to 3.0 mm thick steel sheet, PN-EN 10346:2015-09 grade DX51D+Z275. The upright side profiles of the door leaf carry two sliding blocks each with 2.0 mm angle bars of galvanized steel sheet, which form vertical labyrinth closures. The vertical labyrinth closures have intumescent seals along the whole height, P/N PRO<sub>MM</sub>15. The steel bracing profile is clad in fire-proof panel strips, P/N PRO<sub>MM</sub>11. The steel closing profiles act as vertical labyrinth closures which have intumescent seals along the whole height, P/N PRO<sub>MM</sub>15.

The labyrinth edges of the door leaf are finished with 0.5 to 0.7 mm thick steel sheet profiles, PN-EN 10346:2015-09 grade DX51D+Z275, attached with steel rivets to the door leaf cladding sheets.



**Door leaf specifications**

Specification	U.m.	Value	Notes
Width / height / thickness	mm	So <sup>1)</sup> + 225 / Ho <sup>2)</sup> + 145 / 60	-
Colour	-	Any in the RAL palette on request	Standard colours: RAL 9002, 9010, 7035
Quantity	pcs.	1	-
Total weight	kg / m <sup>2</sup>	30.0	-

1) – Door (construction partition) clear opening width; 2) – Door clear height

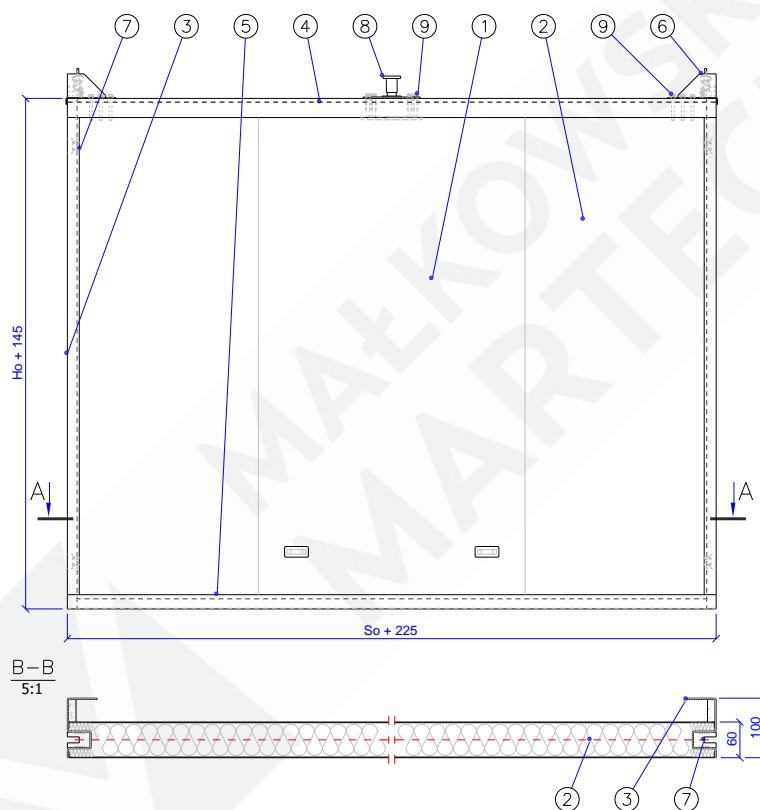
**Fig. 2 – MARC-O60-01.01.00 [Door leaf]**

 1 – Middle panel; 2 – End panel; 3 – Side hardware with stop; 4 – Top hardware with stop; 5 – Bottom hardware;  
 6 – Safety brake; 7 – Sliding block; 8 – E-mag holder lock; 9 – M12x120 bolt

**Door leaf: list of components**

#	Designation	Fig.	Replacement / Repair			Notes
			U <sup>1)</sup>	A <sup>2)</sup>	P <sup>3)</sup>	
1	Middle panel	*	-	-	YES	* – Depends on the door width
2	End panel	2	-	-	YES	-
3	Side hardware w/stop	2	-	YES	YES	-
4	Top hardware w/stop	1	-	YES	YES	-



5	Bottom hardware	1	-	YES	YES	-
6	Safety brake	2	-	YES	YES	-
7	Sliding block	4	-	YES	YES	-
8	E-mag holder lock	1*	-	YES	YES	* - 2 if So > 4500 mm
9	M12 x 120 hex head bolt	8	-	YES	YES	PN-EN ISO 4017 / DIN 933, class 8.8

1) – Done by the user, 2) – Done by the authorized service, 3) – Done by the manufacturer

**CAUTION!** If the parts to be serviced by manufacturer only is replaced by anyone else, it will immediately void the CE marking of the door and the door's performance, including the fire resistance rating.

## 6.2 WALL STOP

Wall stops mate with the labyrinth closures of the door clear opening. They are installed along each edge of the door opening.

Each stop is made of a Z-profile formed from 2.0 mm thick steel sheet, PN-EN 10346:2015-09 grade DX51D+Z275, and clad in fire-proof panel strips, P/N PRO<sub>MM</sub>3, topped by a steel sheet fascia of the same steel grade and 0.5 to 0.7 mm thick.

Intumescent seals, P/N PRO<sub>MM</sub>15 are installed along the whole stop profile.

### Wall stop specifications

Specification	U.m.	Value	Notes
Width / height / length	mm	90 / 45 / So <sup>1)</sup> + 200 90 / 45 / Ho <sup>2)</sup> + 100	-
Colour	-	Any in the RAL palette on request	Standard colours: RAL 9002, 9010, 7035
Quantity per door	sets	3*	* – 2 vertical + 1 horizontal
Total weight	kg/m	3.25	-

1) – Door (construction partition) clear opening width; 2) – Door clear height

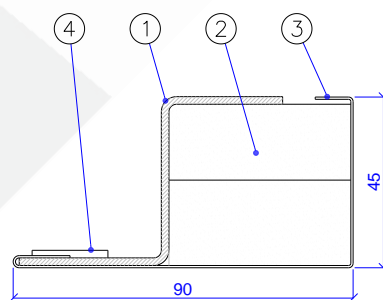

**Fig. 3 – MARC-O60-01.02.00 [Wall stop]**

1 – Rail; 2 – Rail union; 3 – Fascia installation profile





<b>MAŁKOWSKI MARTECH</b> Czołowo, ul. Leśna 57, 62-035 Kórnik phone: +48 61 222 75 00 fax: +48 61 222 75 01 email: biuro@malkowski.pl, www.malkowski.pl	<b>OVERHEAD FIRE DOOR type: MARC-O EI60</b>	Ref. no.: <b>ISOIK_O-1</b>
	<b>INSTRUCTIONS FOR USE, OPERATION AND MAINTENANCE</b>	Revision: <b>03/2021</b>

### Wall stop: list of components

#	Designation	Fig.	Replacement / Repair			Notes
			U <sup>1)</sup>	A <sup>2)</sup>	P <sup>3)</sup>	
1	Stop profile	1	-	YES	YES	-
2	Fire-proof panel	1	-	YES	YES	-
3	Fascia	1	-	YES	YES	-
4	Expanding seal	1		YES	YES	PRO <sub>MM</sub> 15

1) – Done by the user, 2) – Done by the authorized service, 3) – Done by the manufacturer

**CAUTION!** If the parts to be serviced by manufacturer only is replaced by anyone else, it will immediately void the CE marking of the door and the door's performance, including the fire resistance rating.

### 6.3 DOOR GUIDE RAIL ASSEMBLY

Type MARC-O overhead fire door is provided with two guide rail assemblies, each on the opposite vertical edge of the opening within which the door leaf runs.

Each guide rail assembly comprises the main profile, formed from 3.0 to 5.0 mm thick steel sheet PN-EN 10346:2015-09 grade DX51D+Z275. This profile fastens the guide rail to the construction partition. The anchoring element type depends on the building partition material.

There are – tack welded or fastened with steel self-drilling sheet screws to the main profile edge square to the construction partition – the guide profiles made from 1.0 to 2.0 mm thick galvanized steel sheet, PN-EN 10346:2015-09 grade DX51D+Z275.

On the opposite side there is a set of fire-proof panels fastened the overall length of which is the door opening height + 100 mm.

The edge in contact with the construction partition is attached to the counterweight guide rail, made from 2.0 mm thick galvanized steel sheet, PN-EN 10346:2015-09 grade DX51D+Z275.

#### Door guide rail assembly specifications

Specification	U.m.	Value	Notes
Width / height / length	mm	331 x 171 x 2Ho <sup>1)</sup> + 345	-
Colour	-	galvanized	Any in the RAL palette on request
Quantity	pcs.	2	-
Total weight	kg/m	19.00	-

1) – Door (partition) clear height

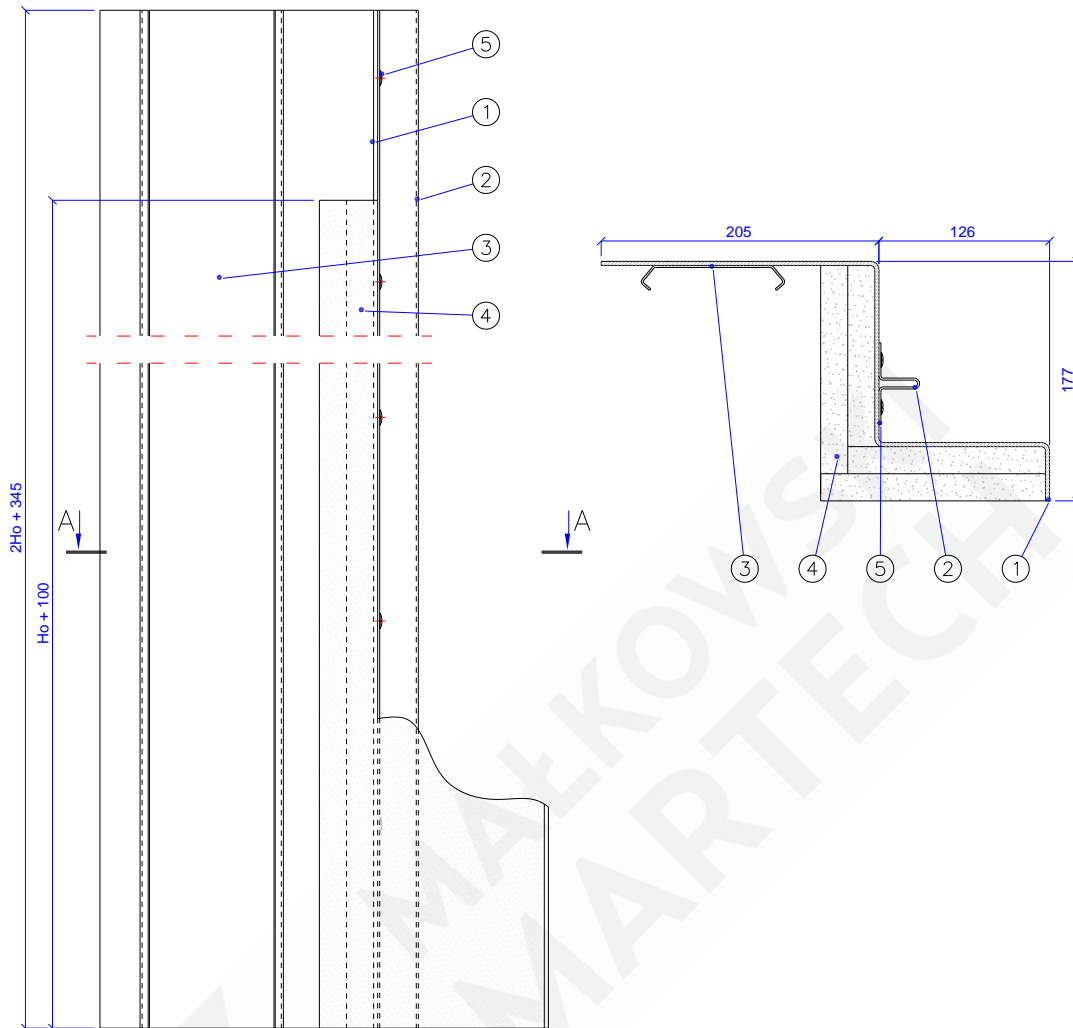

**Fig. 4 – MARC-O60-01.03.00 [Door leaf guide rail assembly]**

1 – Main profile; 2 – Door leaf guide; 3 – Counterweight guide; 4 – Fire-proof panel; 5 – 4.2x13 mm self-drilling screw

**Door leaf guide rail assembly: list of components**

#	Designation	Fig.	Replacement / Repair			Notes
			U <sup>1)</sup>	A <sup>2)</sup>	P <sup>3)</sup>	
1	Main profile	*	-	-	YES	-
2	Door leaf guide	1	-	YES	YES	-
3	Counterweight guide	1	-	YES	YES	-
4	Fire-proof panel	4	-	YES	YES	-
5	4.2x13 mm self-drilling screw	4*	-	YES	YES	* – Every 500 mm; DIN 7504 T

1) – Done by the user, 2) – Done by the authorized service, 3) – Done by the manufacturer

**CAUTION!** If the parts to be serviced by manufacturer only is replaced by anyone else, it will immediately void the CE marking of the door and the door's performance, including the fire resistance rating.



#### 6.4 CABLE/BELT PULLEY ASSEMBLY

The cable/belt pulley assembly comprises two components: the pulley assembly and its wall bracket. The pulley assembly is a steel pulley (with the valley to guide the steel cable) with a yoke. The wall bracket is a weldment made of 8.0 mm thick pieces of structural steel. The pulley assembly is fastened to the wall bracket with M12 x 35 bolts, M12 hex nuts, and plain washers. The belt pulley assembly has the cable pulley replaced with a belt pulley.

##### Cable/belt pulley assembly specifications

Specification	U.m.	Value	Notes
Width / height / length	mm	140 / 140 / 230	-
Colour	-	galvanized	Any in the RAL palette on request
Quantity	pcs.	2	-
Total weight	kg	9.6	-

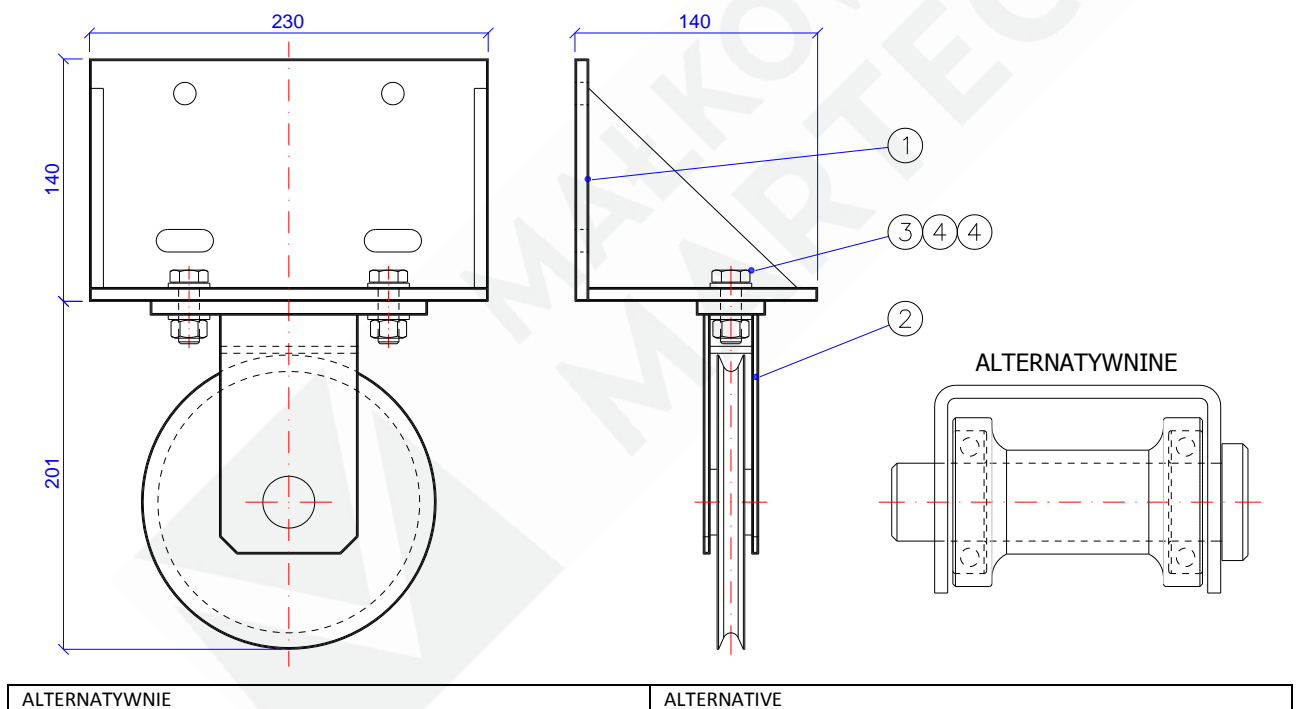

ALTERNATYWNE

ALTERNATIVE

**Fig. 5 – MARC-O60-01.04.00 [Cable/belt pulley assembly]**

1 – Wall bracket; 2 – Pulley assembly; 3 – M12x35 bolt; 4 – 13 mm plain washer; 5 – M12 hex nut



**Cable/belt pulley assembly: list of components**

#	Designation	Fig.	Replacement / Repair			Notes
			U <sup>1)</sup>	A <sup>2)</sup>	P <sup>3)</sup>	
1	Wall bracket	1	-	YES	YES	-
2	Pulley assembly	1	-	YES	YES	-
3	M12 x 35 hex head bolt	2	-	YES	YES	PN-EN ISO 4017 / DIN 933, class 8.8
4	Plain washer, 13, 200 HV	2	-	YES	YES	PN-EN ISO 7089
5	M12 hex nut	2	-	YES	YES	PN-EN ISO 4032, class 8

1) – Done by the user, 2) – Done by the authorized service, 3) – Done by the manufacturer

**CAUTION!** If the parts to be serviced by manufacturer only is replaced by anyone else, it will immediately void the CE marking of the door and the door's performance, including the fire resistance rating.

**6.5 COUNTERWEIGHT ASSEMBLY**

The main component of the counterweight is two steel discs, each measuring 120 mm in diameter (or of another suitable size) and 250 mm in length. The discs are connected to one another with M12 threaded bars. The top part of the counterweight assembly features a lugged nut and the counterweight guide. The bottom part of the counterweight assembly features compensating disks the number of which is determined during the installation process. The bottom end of the entire assembly ends with the opposite counterweight guide and it is secured with two M12 nuts and a washer.

**Counterweight assembly specifications**

Specification	U.m.	Value	Notes
Diameter	mm	120*	* – Standard size; other diameter options are allowed
Colour	-	-	Primer coat
Quantity	sets	2	-
Total weight	kg/m	90.0	-

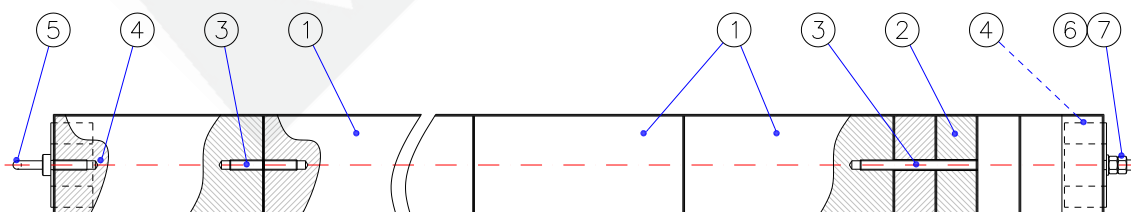
**Fig. 6 – MARC-O60-01.05.00 [Counterweight assembly]**

 1 – 250 mm counterweight bar; 2 – 50 mm counterweight bar; 3 – M12 threaded bar;  
 4 – Counterweight guide; 5 – Rope lugs; 6 – M12 hex nut; 7 – 13.5 mm washer

<b>MAŁKOWSKI MARTECH</b> Czołowo, ul. Leśna 57, 62-035 Kórnik phone: +48 61 222 75 00 fax: +48 61 222 75 01 email: biuro@malkowski.pl, www.malkowski.pl	<b>OVERHEAD FIRE DOOR type: MARC-O EI60</b>	Ref. no.: <b>ISOIK_O-1</b>
	<b>INSTRUCTIONS FOR USE, OPERATION AND MAINTENANCE</b>	Revision: <b>03/2021</b>

### Counterweight assembly: list of components

#	Designation	Fig.	Replacement / Repair			Notes
			U <sup>1)</sup>	A <sup>2)</sup>	P <sup>3)</sup>	
1	250 mm counterweight bar	1	-	YES	YES	-
2	50 mm counterweight bar	*	-	YES	YES	* – The quality depends on the door leaf weight
3	M12 threaded bar	*	-	YES	YES	* – The quality depends on the door leaf weight
4	Counterweight guide	2	-	YES	YES	-
5	Cable lug: M12 lugged nut	1	-	YES	YES	DIN 582, class 8
6	M12 hex nut	2	-	YES	YES	PN-EN ISO 4032, class 8
7	13 mm plain washer	1	-	YES	YES	PN-EN ISO 7089

1) – Done by the user, 2) – Done by the authorized service, 3) – Done by the manufacturer

**CAUTION!** If the parts to be serviced by manufacturer only is replaced by anyone else, it will immediately void the CE marking of the door and the door's performance, including the fire resistance rating.

### 6.6 E-MAG HOLDER ASSEMBLY

The e-mag holder assembly comprises one part which is fastened to the construction partition and the counterpart fastened to the door leaf.

The first part is a wall bracket which carries a bolted lock which mates with the e-mag holder.

A baseplate which carries the e-mag holder lock is bolted to the door leaf.

#### E-mag holder assembly specifications

Specification	U.m.	Value	Notes
Width / height / length	mm	215 / 231* / 60	* – Kit of parts
Colour	-	galvanized	Any in the RAL palette on request, applies to the bracket and the baseplate
Quantity	sets	1	-
Total weight	kg	2.5	-



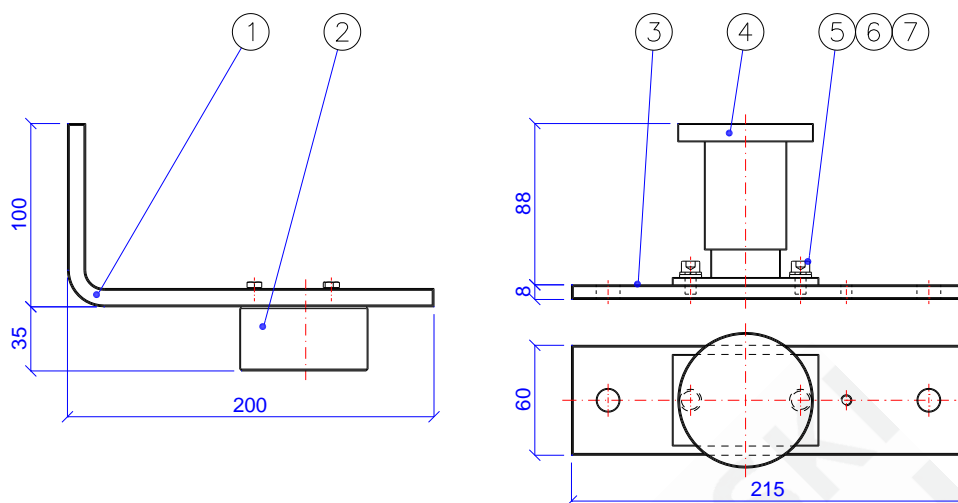

**Fig. 7 – MARC-O60-01.06.00 [E-mag holder assembly]**

 1 – Wall bracket; 2 – E-mag holder; 3 – Baseplate; 4 – E-mag holder lock;  
 5 – M6x16 bolt; 6 – 6.4 mm washer; 7 – 6.1 mm spring washer

**E-mag holder assembly: list of components**

#	Designation	Fig.	Replacement / Repair			Notes
			U <sup>1)</sup>	A <sup>2)</sup>	P <sup>3)</sup>	
1	Wall bracket	1	-	YES	YES	-
2	Electromagnetic holder	1	-	YES	YES	-
3	Baseplate	1	-	YES	YES	-
4	E-mag holder lock	1	-	YES	YES	-
5	M6 x 16 cap bolt	2	-	YES	YES	DIN 912 / ISO 4762
6	6.4 mm plain washer	2	-	YES	YES	PN-EN ISO 7089
7	6.1 mm spring washer	2	-	YES	YES	DIN 127

1) – Done by the user, 2) – Done by the authorized service, 3) – Done by the manufacturer

**CAUTION! If the parts to be serviced by manufacturer only is replaced by anyone else, it will immediately void the CE marking of the door and the door's performance, including the fire resistance rating.**



## 6.7 DOOR GUIDE RAIL FASCIA

The fascia covers the full guide rail assemblies. The fascia is made of 0.7 to 1.0 mm thick steel sheet, PN-EN 10346:2015-09 grade DX51D+Z275.

One side of the fascia is attached to the main profile of the guide rail assembly, while the other is attached to the construction partition with a clip.

### Door guide rail fascia specifications

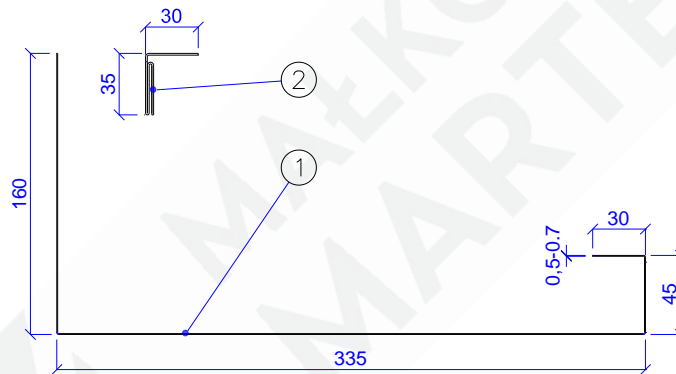
Specification	U.m.	Value	Notes
Width / depth / length	mm	335 / 160 / *	* – Depends on the door height
Colour	-	Any in the RAL palette on request	Standard colours: RAL 9002, 9010, 7035
Quantity	sets	2	-
Total weight	kg/m	2.6–3.6 *	* – Depends on the sheet metal thickness



**Fig. 8 – MARC-O60-01.07.00 [Guide rail assembly fascia]**

1 – Fascia; 2 – Clip

### Guide rail assembly fascia: list of components

#	Designation	Fig.	Replacement / Repair			Notes
			U <sup>1)</sup>	A <sup>2)</sup>	P <sup>3)</sup>	
1	Fascia	1	YES	YES	YES	-
2	Clip	1	-	YES	YES	-

1) – Done by the user, 2) – Done by the authorized service, 3) – Done by the manufacturer

**CAUTION!** If the parts to be serviced by manufacturer only is replaced by anyone else, it will immediately void the CE marking of the door and the door's performance, including the fire resistance rating.

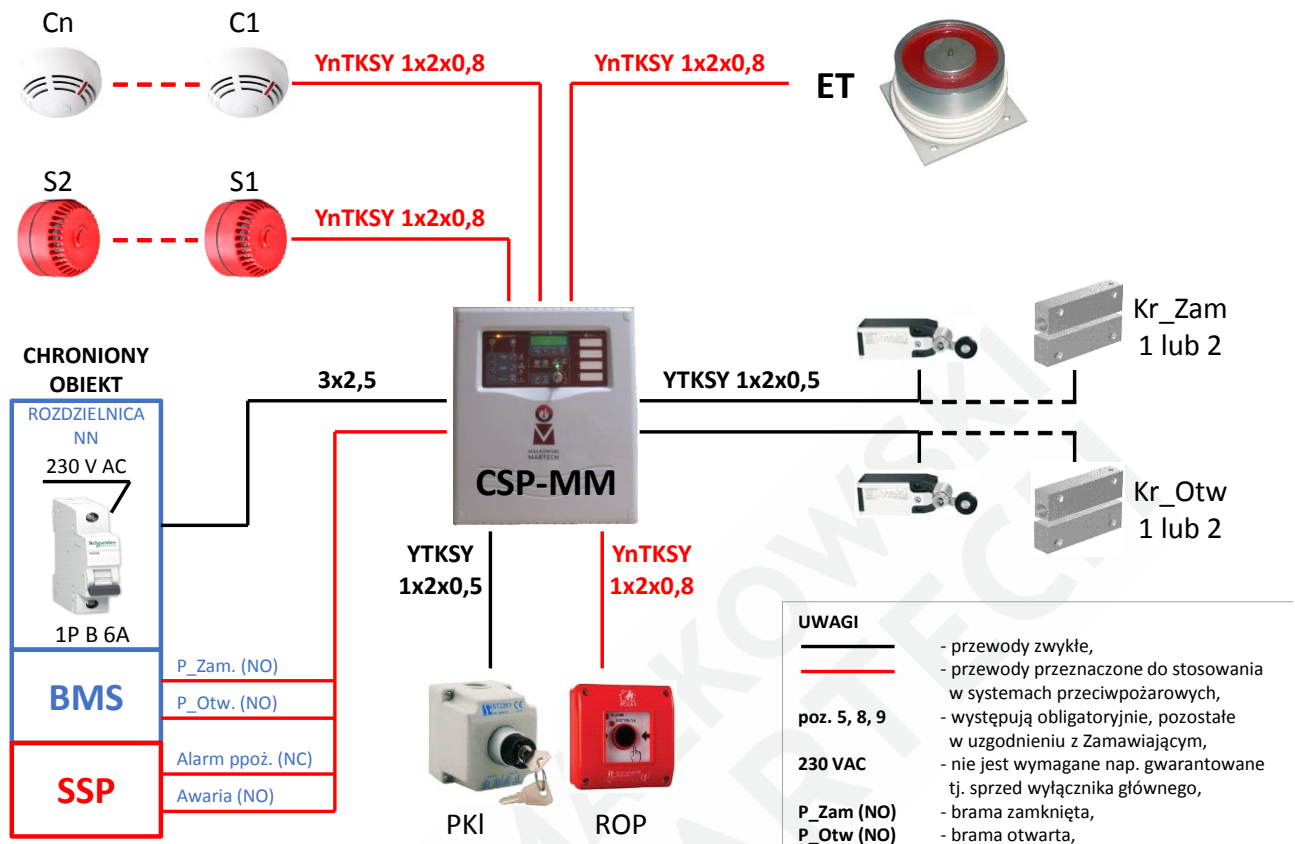

**6.8 VIC-EH ELECTRICAL ACCESSORIES KIT**

CHRONIONY OBIEKT	MONITORED BLDG
ROZDZIELNICA NN	LV SWITCHGEAR
P_Zam. (NO)	G_close (NO)
P_Otw. (NO)	G_open (NO)
Alarm ppoż. (NC)	Fire alarm (NC)
Awaria (NO)	Failure (NO)
Kr_Zam	LS_close
Kr_Otw	LS_open
1 lub 2	1 or 2
UWAGI	NOTES
przewody zwykłe	Regular wires
przewody przeznaczone do stosowania w systemach przeciwpożarowych	Fire alarm system rated wires
występują obligatoryjnie, pozostałe w uzgodnieniu z Zamawiającym	Obligatory, others TBA with the project owner
nie jest wymagane nap. gwarantowane tj. sprzed wyłącznika głównego	Uninterruptible voltage from upstream of the main switch is not required
brama zamknięta	Door / gate closed
brama otwarta	Door / gate open

**Fig. 9 – Marc-O control system with the electromagnetic holder**

#	Figure item	Item type	Item designation	Item code	Recommended qty	Notes
1	C1 - Cn	Spot-type fire detector	Optical smoke detector	DRP-100	2	Recommended: DRP-100 max. 32 pcs.
			Class A1R heat detector	DCP-100	2	
			Multi-vector smoke and heat detector	DMP-100	2	



2	C1 - Cn	Detector receptacle	Standard fire detector receptacle	DB100	2	Quantity equal to the number of detectors
3	ROP	Manual call point	Standard manual call point	ROP-100/PL	1	max. 10 pcs.
4	S1, S2	Fire alarm indicator	Fire alarm sounder, low base	SPP-100	1	max. 2 lines
5	ET	Electromagnetic holder	Land holder	EM-xxxx	1	-
6	LS_close	Limit switch 1 Mag. sensor 2	Mecha. limit switch Magnetic reed relay switch	KB F1 S11 MS-240-S45	1	Application option, selection 1 or 2
7	LS_open	Limit switch 1 Mag. sensor 2	Mecha. limit switch Magnetic reed relay switch	KB F1 S11 MS-240-S46	1	Application option, selection 1 or 2
8	PKI	Key switch	Key operated switch K1, hand operation	SP22K1/07-1	1	-
9	CSP-MM	Control unit	Universal drive controller	CSP-MM 1(2)	1	-

### 6.9 VIC-040x ELECTRICAL ACCESSORIES KIT

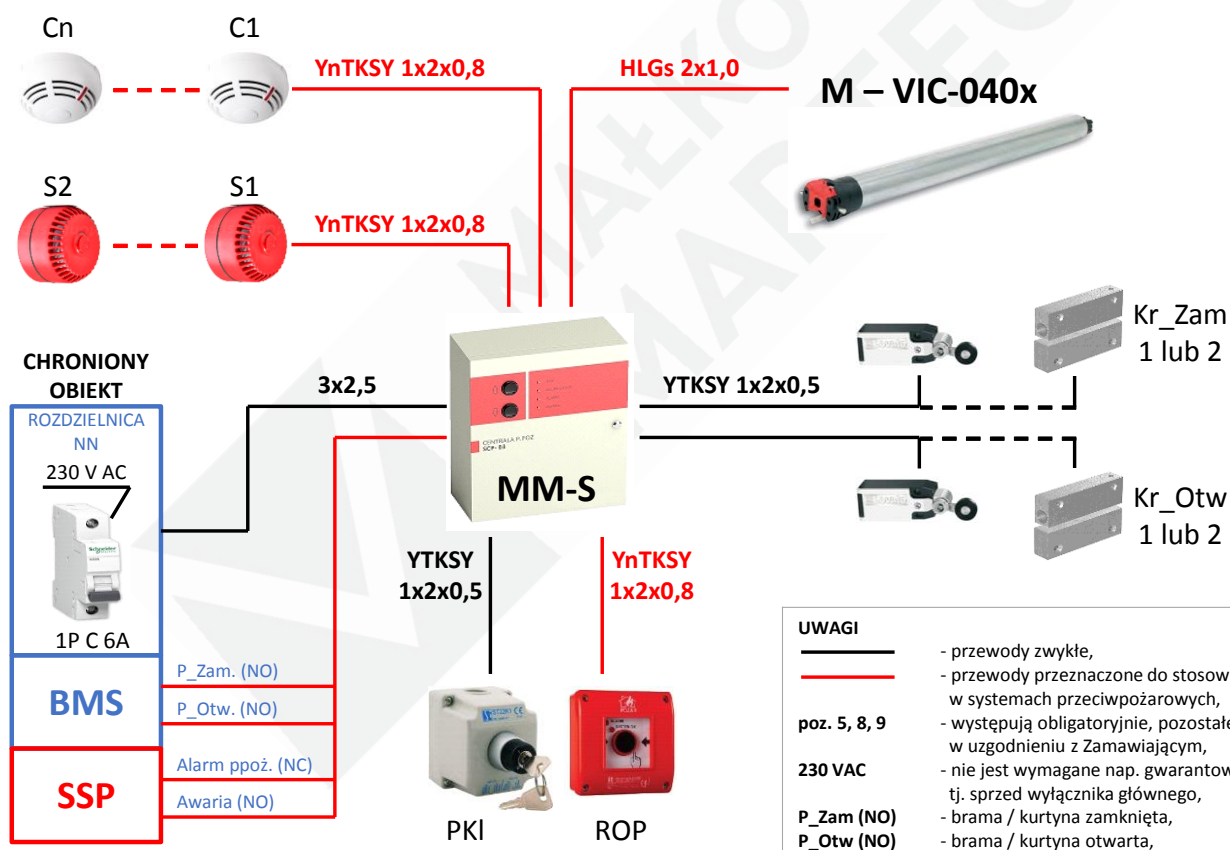

CHRONIONY OBIEKT	MONITORED BLDG
ROZDZIELNICA NN	LV SWITCHGEAR
P_Zam. (NO)	G_close (NO)
P_Otw. (NO)	G_open (NO)
Alarm ppoż. (NC)	Fire alarm (NC)
Awaria (NO)	Failure (NO)
Kr_Zam	LS_close
Kr_Otw	LS_open
1 lub 2	1 or 2



<b>MAŁKOWSKI MARTECH</b> Czołowo, ul. Leśna 57, 62-035 Kórnik phone: +48 61 222 75 00 fax: +48 61 222 75 01 email: biuro@malkowski.pl, www.malkowski.pl	<b>OVERHEAD FIRE DOOR type: MARC-O EI60</b>	Ref. no.: <b>ISOIK_O-1</b>
	<b>INSTRUCTIONS FOR USE, OPERATION AND MAINTENANCE</b>	Revision: <b>03/2021</b>

UWAGI	NOTES
przewody zwykłe	Regular wires
przewody przeznaczone do stosowania w systemach przeciwpożarowych	Fire alarm system rated wires
występują obligatoryjnie, pozostałe w uzgodnieniu z Zamawiającym	Obligatory, others TBA with the project owner
nie jest wymagane nap. gwarantowane tj. sprzed wyłącznika głównego	Uninterruptible voltage from upstream of the main switch is not required
brama / kurtyna zamknięta	Gate / door / curtain closed
brama / kurtyna otwarta	Gate / door / curtain open

**Fig. 10 – MARC-O control system with internal (tubular) 24 V DC drive unit**

#	Figure item	Item type	Item designation	Item code	Recommended qty	Notes
1	C1 - Cn	Spot-type fire detector	Optical smoke detector	ID100	2	Recommended: ID100, max. 6 pcs.
			Class A1R heat detector	ID200	2	
			Smoke and heat detector	ID300	2	
2	C1 - Cn	Detector receptacle	Standard fire detector receptacle	EB0010	2	Quantity equal to the number of detectors
3	ROP	Manual call point	Standard manual call point	ROP OP1	1	max. 10 pcs.
4	S1, S2	Fire alarm indicator	Fire alarm sounder, low base	SPP-100	1	max. current 200 mA
5	M	Electric drive	internal (tubular)	VIC-040x	1	-
6	LS_close	Limit switch 1 Mag. sensor 2	Mecha. limit switch Magnetic reed relay switch	KB F1 S11 MS-240-S45	1	Application option, selection 1 or 2
7	LS_open	Limit switch 1 Mag. sensor 2	Mecha. limit switch Magnetic reed relay switch	KB F1 S11 MS-240-S46	1	Application option, selection 1 or 2
8	PKI	Key switch	Key operated switch K1, hand operation	SP22K1/07-1	1	-
9	MM-S	Control unit	Universal drive controller	MM-S	1	-



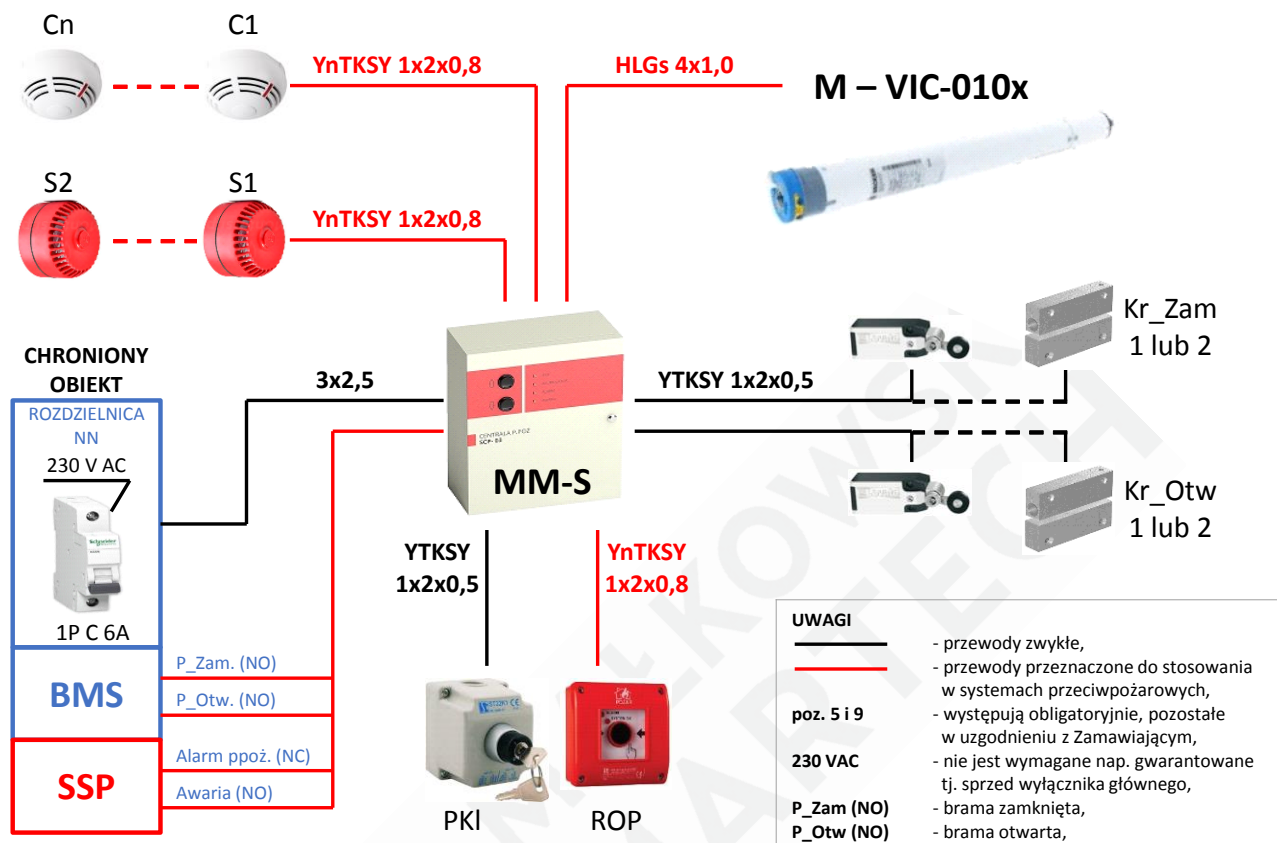

**6.10 VIC-010x ELECTRICAL ACCESSORIES KIT**

CHRONIONY OBIEKT	MONITORED BLDG
ROZDZIELNICA NN	LV SWITCHGEAR
P_Zam. (NO)	G_close (NO)
P_Otw. (NO)	G_open (NO)
Alarm ppoż. (NC)	Fire alarm (NC)
Awaria (NO)	Failure (NO)
Kr_Zam	LS_close
Kr_Otw	LS_open
1 lub 2	1 or 2
UWAGI	NOTES
przewody zwykłe	Regular wires
przewody przeznaczone do stosowania w systemach przeciwpożarowych	Fire alarm system rated wires
występują obligatoryjnie, pozostałe w uzgodnieniu z Zamawiającym	Obligatory, others TBA with the project owner
nie jest wymagane nap. gwarantowane tj. sprzed wyłącznika głównego	Uninterruptible voltage from upstream of the main switch is not required
brama zamknięta	Door / gate closed
brama otwarta	Door / gate open

**Fig. 11 – MARC-O control system with internal (tubular) 24 V DC drive unit**

#	Figure item	Item type	Item designation	Item code	Recommended qty	Notes
1	C1 - Cn	Spot-type fire detector	Optical smoke detector	ID100	2	Recommended: ID100, max. 6 pcs.
			Class A1R heat detector	ID200	2	



			Smoke and heat detector	ID300	2	
2	C1 - Cn	Detector receptacle	Standard fire detector receptacle	EB0010	2	Quantity equal to the number of detectors
3	ROP	Manual call point	Standard manual call point	ROP OP1	1	max. 10 pcs.
4	S1, S2	Fire alarm indicator	Fire alarm sounder, low base	SPP-100	1	max. current 200 mA
5	M	Electric drive	internal (tubular)	VIC-010x	1	-
6	LS_close	Limit switch 1 Mag. sensor 2	Mecha. limit switch Magnetic reed relay switch	KB F1 S11 MS-240-S45	1	Application option, selection 1 or 2
7	LS_open	Limit switch 1 Mag. sensor 2	Mecha. limit switch Magnetic reed relay switch	KB F1 S11 MS-240-S46	1	Application option, selection 1 or 2
8	PKI	Key switch	Key operated switch K1, hand operation	SP22K1/07-1	1	-
9	MM-S	Control unit	Universal drive controller	MM-S	1	-

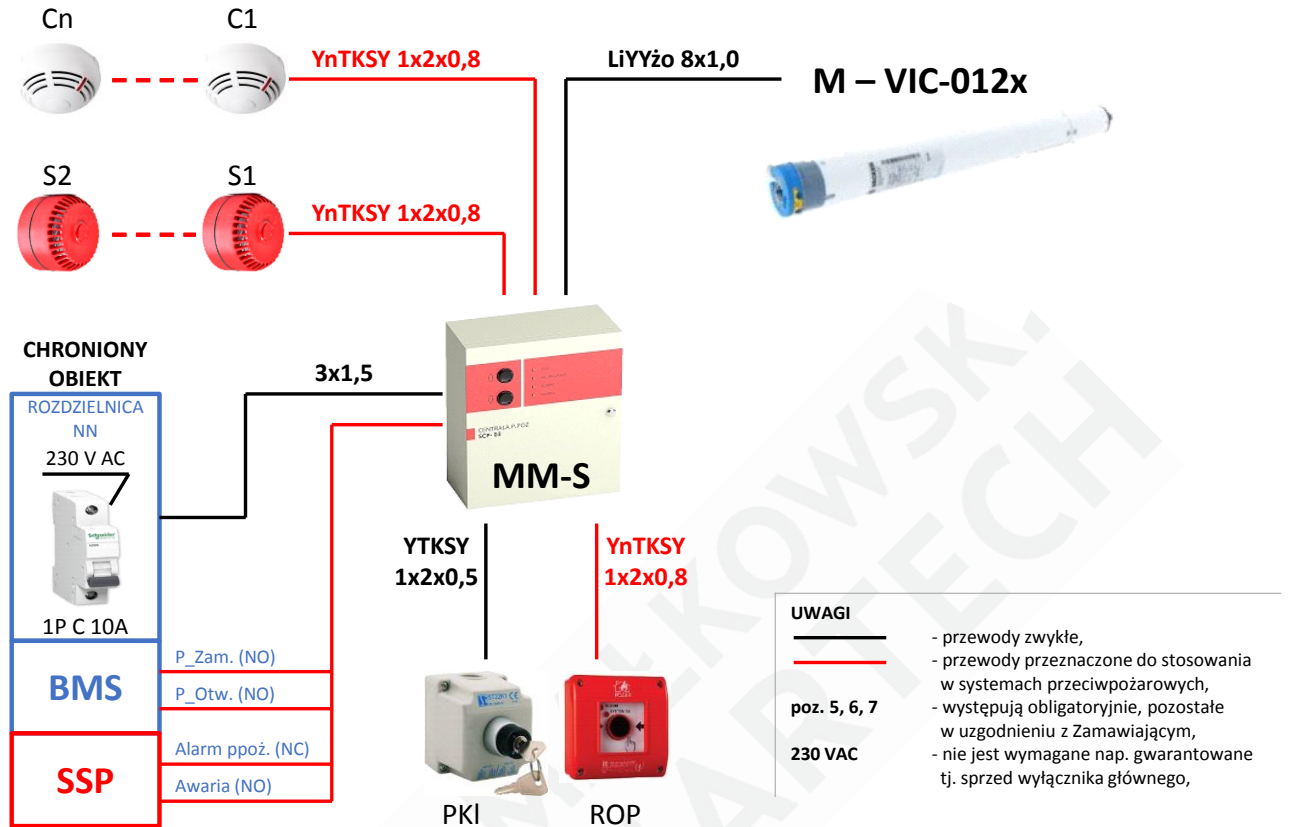

**6.11 VIC-012x ELECTRICAL ACCESSORIES KIT**

CHRONIONY OBIEKT	MONITORED BLDG
ROZDZIELNICA NN	LV SWITCHGEAR
P_Zam. (NO)	G_close (NO)
P_Otw. (NO)	G_open (NO)
Alarm ppoż. (NC)	Fire alarm (NC)
Awaria (NO)	Failure (NO)
UWAGI	NOTES
przewody zwykłe	Regular wires
przewody przeznaczone do stosowania w systemach przeciwpożarowych	Fire alarm system rated wires
występują obowiązkowo, pozostałe w uzgodnieniu z Zamawiającym	Obligatory, others TBA with the project owner
nie jest wymagane nap. gwarantowane tj. sprzed wyłącznika głównego	Uninterruptible voltage from upstream of the main switch is not required

**Fig. 12 – MARC-O control system with internal (tubular) 230 V AC drive unit (gravity-operated closing motion)**

#	Figure item	Item type	Item designation	Item code	Recommended qty	Notes
1	C1 - Cn	Spot-type fire detector	Optical smoke detector	ID100	2	Recommended: ID100, max. 6 pcs.
			Class A1R heat detector	ID200	2	
			Smoke and heat detector	ID300	2	
2	C1 - Cn	Detector receptacle	Standard fire detector receptacle	EB0010	2	Quantity equal to the number of detectors



<b>MAŁKOWSKI MARTECH</b> Czołowo, ul. Leśna 57, 62-035 Kórnik phone: +48 61 222 75 00 fax: +48 61 222 75 01 email: biuro@malkowski.pl, www.malkowski.pl	<b>OVERHEAD FIRE DOOR type: MARC–O EI60</b>	Ref. no.: <b>ISOIK_O-1</b>
	<b>INSTRUCTIONS FOR USE, OPERATION AND MAINTENANCE</b>	Revision: <b>03/2021</b>

3	ROP	Manual call point	Standard manual call point	ROP OP1	1	max. 10 pcs.
4	S1, S2	Fire alarm indicator	Fire alarm sounder, low base	SPP-100	1	max. current 200 mA
5	M	Electric drive	internal (tubular)	VIC-012x	1	-
6	PKI	Key switch	Key operated switch K1, hand operation	SP22K1/07-1	1	-
7	MM-S	Control unit	Universal drive controller	MM-S	1	-

## 7. TROUBLESHOOTING

Every failure of the fire door shall be reported to the manufacturer and removed by authorized personnel strictly as instructed by the manufacturer (ref. Section 8 INSPECTION, MAINTENANCE, AND REPAIRS).

Fault type	Fault cause(s) / operating error	Remedy by operators
The door leaf fails to close / open	Guide rails obstructed or damaged	Call the Technical Service to clear or replace the running rail
	Structural component damage	Call the Technical Service to repair or replace the failed part(s)
	Counterweight stuck	
Fire detector inoperative / fails to trigger the control system	Dirty or damaged	Call the Technical Service to clean, readjust, or replace the part(s)
Fire alarm sounder/beacon fails to come on	System component failure	
Local control system (control panel) indicates an error		Call the Technical Service to troubleshoot
Manual call point does not work / has failed	MCP glass broken	Call the Technical Service to replace the part(s)

## 8. INSPECTION, MAINTENANCE, AND REPAIRS

### 8.1 INSPECTION & MAINTENANCE SCHEDULE

The fire door shall be inspected, maintained and repaired by personnel with sufficient qualifications and professional experience for these tasks.

The fire door manufacturer or its authorized installation contractors (ref. the guidelines in Section 1 INTRODUCTION and Section 2.4 SERVICE PERSONNEL REQUIREMENTS in this Manual) provide paid service inspections, maintenance, repairs, and troubleshooting according to the specific sales contract. This personnel have the required technical resources, spare parts, and qualifications.

Send your service requests for these tasks to the MAŁKOWSKI-MARTECH S.A. Technical Service, (serwis@malkowski.pl or fax: + 48 61 22 27 501). The Technical Service contact details are also on the manufacturer's official website and in the Warranty Certificate.

The inspections and maintenance must be done in compliance with this Manual (ref. the guidelines in the schedule tables below) to ensure correct and safe operation; they are prerequisite to maintain the declared performance of the overhead fire door and during the warranty period, otherwise the warranty rights and liability will be made void.



Inspection type	Frequency	Ownership
Pre-operation inspection	Before each use (does not apply to a fire emergency)	Operator
Monthly inspection	Every 1 month	
Service inspection and maintenance	Every 6 months	Authorized technical service

**S** – Check, inspect, clean; **X** – Adjust and lubricate

### Inspection & maintenance schedule

Assembly / component	Tasks required	Before each use	Every 1 month	Every 6 months
<b>Whole product</b>				
Product structure	Check the painted surfaces (for dirt, etc.) and clean as required.		S	S
	Check that no part is missing and there is no evidence of damage of failure from operation.	S	S	S
	Check the door's identification markings (the nameplate must be present and legible).		S	S
Door leaf.	Check for dirt, damage, etc.; clean as required.	S	S	S
Brackets, guards, fascias	Check the fasteners and their condition			S
<b>Door leaf closing/opening drive</b>				
Guide rail	Check the fasteners and the component's condition; look for obstructions.			S
Counterweight system	Check the cable fastening and condition.			S
	Check that the movement is unobstructed; lubricate as required <sup>1)</sup> .		S	S
<b>Electrical / control system</b>				
All electrical accessories	Trigger the sensors/detectors to test for proper operation of the accessories kit; readjust as required.			SX
Fire detector	Check the condition and clean the component; readjust as required.			SX
Manual call point	Check the condition and test the operation.			S
Control unit (panel)	Test the operation of all control panel components.			S
	Check for error displays.	S	S	S
Key switch	Check the condition and test the operation.		S	S
Electric drive motor	Check the condition and test the operation (the component must run smoothly and without stuttering, audible noise, and evident vibration).		S	S
Battery pack	Inspect the terminals and wiring; clean and lubricate as required <sup>1)</sup> .		S	SX
	Check the battery acid level and state of charge; refill with battery acid and recharge as required.		S	S
Electrical wiring system <sup>2)</sup>	Inspect the fastening and condition of fittings and cable trays.		S	S

1) – Petroleum jelly is recommended.

2) – Power wiring insulation resistance tests and wiring continuity tests are to be done at least every 5 years.



<b>MAŁKOWSKI MARTECH</b> Czołowo, ul. Leśna 57, 62-035 Kórnik phone: +48 61 222 75 00 fax: +48 61 222 75 01 email: biuro@malkowski.pl, www.malkowski.pl	<b>OVERHEAD FIRE DOOR type: MARC–O EI60</b>	Ref. no.: <b>ISOIK_O-1</b>
	<b>INSTRUCTIONS FOR USE, OPERATION AND MAINTENANCE</b>	Revision: <b>03/2021</b>

All worn or damaged parts shall be replaced with new counterparts only. Maintain and repair with genuine components and parts which are approved by the fire door manufacturer. Each inspection, maintenance, and repair shall be completed and certified by the authorized personnel according to the scheduled scope in the Periodic Inspection and Maintenance Log (appended to this Manual in chapter 11 – APPENDICES) or in a separate certificate.

The fire door user shall retain all records of inspections, maintenance, repairs, and overhauls.

## 8.2 OPERATOR'S INSPECTIONS

The operator's inspections shall be done by the operator assigned by the product's user and trained by the fire door manufacturer or its authorized installation contractor (ref. also the guidelines in Section 2.4 SERVICE PERSONNEL REQUIREMENTS and Section 8.1 INSPECTION & MAINTENANCE SCHEDULE).

Wear basic PPE (personal protection equipment) e.g. rubber gloves etc. during each inspection service.

If the fire door fails, is damaged, or found to operate incorrectly, notify the site supervisors and the manufacturer or its authorized installation contractor.

## 8.3 SERVICE INSPECTIONS & MAINTENANCE

The technical services of the manufacturer are provided by qualified and professionally experienced service technicians of MAŁKOWSKI-MARTECH S.A. or its contractors who are authorized for servicing the fire door.

To verify for the buyer that the service is provided by a fully professional/authorized contractor or technician, the latter should hold and present their Installation Authorization Certificate, while the service technicians should hold and present their Site Authorized Service Certificate issued by the fire door manufacturer, MAŁKOWSKI-MARTECH S.A.

In the Lists of Components and Parts, ref. Section 6 TECHNICAL SPECIFICATIONS of this Manual, the fire door manufacturer specifies the ownership and right of repair/replacement of components, assemblies, and parts; failure in compliance to these specifications will void the product warranty and declaration of performance.

### CAUTION!

**Pursuant to the Polish Regulation ref. Dz.U.2010.109.719, as amended: §3.2 "Fire protection equipment (...) shall be technically inspected and maintained in compliance with the procedures and methods established in the Polish Standards [PN] concerning fire protection equipment and fire extinguishers, the equipment's operating and maintenance manuals, and the user manuals issued by the respective equipment manufacturers." §3.3 "Technical inspections and maintenance shall be carried out with the frequency established by the respective manufacturer and at least once a year."**

**The service inspections, maintenance, repairs, and overhaul of the fire door shall only be done by trained personnel of the manufacturer or its authorized service contractor.**

The fire door user or the personnel or contractor it has authorized is liable for collection and retention of documented proof that the service inspections and maintenance are carried out at least every six months, unless specified otherwise in the sale contract (or special requirements/site conditions of the user require other frequency of the service inspections and maintenance).





## 8.4 CLEANING

The operating personnel is required to keep the work place and the fire door clean. Clean with commercially available household cleaning products, e.g. dishwashing liquids.

Do not use aggressive cleaners or organic solvents, or pressure washing (with water or other liquids). If the fire door is contaminated with insoluble substances, remove them mechanically without damage to the paint coat or scratching the product's surfaces.

## 8.5 REPLACEMENT PARTS

Order the replacement parts by specifying the production year of the fire door and the part numbers, designations, and quantity.

ALL REPLACEMENT PARTS USED FOR INSPECTION, MAINTENANCE, REPAIRS, AND OVERHAULS SHALL BE GENUINE SPARE PARTS SPECIFIED BY THE MANUFACTURER IN THE LISTS OF "COMPONENTS AND PARTS" IN SECTION 6 TECHNICAL SPECIFICATIONS OF THIS MANUAL.

## 9. DISPOSAL

Dispose of the fire door and all its worn out parts in compliance with applicable regulations of law.

When the fire door or any of its parts reaches its end of life and requires dismantling and disposal:

- Remove the door components and electrical system by performing the assembly and installation in the reverse order, and follow by handing over the parts (like the electric motor) for waste recovery.
- Hand over all plastic, rubber, and mineral wool parts for disposal.
- Cut and scrap the steel structure, metal sheets, profiles, bars and other hardware with all other steel parts (including anchors, plugs, and bolts).

### 9.1 CHEMICAL NOTICE



None of the overhead fire door components contains asbestos or coatings or elements which release any gases harmful to the ozone layer. The pigments and anti-corrosive treatment of the structure and components are free of cadmium, chromium and other air and soil aquifer layer pollutants.



<b>MAŁKOWSKI MARTECH</b> Czołowo, ul. Leśna 57, 62-035 Kórnik phone: +48 61 222 75 00 fax: +48 61 222 75 01 email: biuro@malkowski.pl, www.malkowski.pl	<b>OVERHEAD FIRE DOOR type: MARC–O EI60</b>	Ref. no.: <b>ISOIK_O-1</b>
	<b>INSTRUCTIONS FOR USE, OPERATION AND MAINTENANCE</b>	Revision: <b>03/2021</b>

## 10. IDENTIFICATION

Type MARC-O overhead fire door is identified with the nameplate the specimen of which is shown below. The parameters of the delivered fire door are featured on the nameplate.

 <b>2434</b>
 <b>MAŁKOWSKI MARTECH</b> <b>MAŁKOWSKI-MARTECH S.A.</b> Czołowo ul. Leśna 57 62-035 Kórnik 20 <b>Declaration of Performance No.</b> ...../CPR/MARC–O/2020 - PL
<b>EN 16034:2014</b> <b>Fire door,</b> <b>single-leaf, overhead</b> <b>MARC®-O EI60</b>  <b>Intended use:</b> Installation in fire partitions  <b>Fire resistance:</b> EI <sub>2</sub> 60  <b>Ability to release:</b> Released  <b>Self-closing rating:</b> C  <b>Ability to release durability:</b> Sustained release  <b>Self-closing durability related to degradation:</b> Use category: .....  <b>Self-closing durability related to weathering (corrosion)</b> Achieved  <b>EN 13241:2003+A2:2016</b> <b>Resistance to wind load:</b> Class .....
<b>Serial number: ..... / 202...</b>

**Fig. 13 – Specimen of the nameplate of the overhead fire door (ref. EN 16034:2014-11)**

The nameplate is factory applied on the door leaf, near the flush pull.



**11. APPENDICES**

- Periodic Inspection and Maintenance Log
- Warranty Certificate (SPECIMEN)
- Copy of the Declaration of Performance
- Available to the manufacturer-issued Installation Authorization Certificate holders:
  - VIC electrical accessories kit installation manual
  - Type MARC–O EI60 overhead fire door installation manual



**PERIODIC INSPECTION AND MAINTENANCE LOG**

Equipment type:	Serial number:	Year of production:
-----------------	----------------	---------------------

#	Completed service(s)	Date & authorized stamp and signature	Notes
1			
2			
3			
4			
6			
7			
8			
9			
10			
11			
12			
13			
14			
15			
16			
17			
18			
19			
20			



<b>MAŁKOWSKI MARTECH</b> Czołowo, ul. Leśna 57, 62-035 Kórnik phone: +48 61 222 75 00 fax: +48 61 222 75 01 email: biuro@malkowski.pl, www.malkowski.pl	<b>OVERHEAD FIRE DOOR type: MARC-O EI60</b>	Ref. no.: <b>ISOIK_O-1</b>
	<b>INSTRUCTIONS FOR USE, OPERATION AND MAINTENANCE</b>	Revision: <b>03/2021</b>

### WARRANTY CERTIFICATE

Warranty issued to the Buyer / Warranty Rights Owner*:		Installation location*:		
Warranty period*:		Ref. Contract/P.O. No.*:		
#	Sold product	Additional description*:	Identification no.*:	Quantity (pcs)*:
1	Single-leaf overhead fire door MARC-O EI60	EI60		1
2	Local control system (control panel)	CSP M-M		1
3	Fire detector, thermal	DRP-100		2
4	Manual call point	ROP-100/PL		1
5	Alarm sounder & beacon	SPP-100		1

#### § 1

##### Shipping; acceptance; pre-installation work

1. The quantity acceptance of the product is done prior to outbound shipping and at the site of MAŁKOWSKI-MARTECH S.A. (hereinafter, the Guarantor). The signature of the Installer/Buyer on the Goods Issue Note provided with the sold product certifies that the product is complete and conforms with the specifications in the Goods Issue Note.
2. Before the product is assembled/installed, the Installer shall carefully verify that the product has not been damaged in transport, remains of full value, and conforms to the purchase order submitted by the Buyer. If the product is found not to be conformity with the purchase order and/or any defect is found in the product, do not proceed with the assembly and installation process; immediately notify the Guarantor.
3. If the product's defect(s) could have been reasonably found with due diligence prior to the assembly and installation process, all WARRANTY CLAIMS for the defect(s) submitted once the product is assembled and installed will be rejected without examination.

#### § 2

##### General warranty terms and conditions

1. The Warranty Rights Owner will retain its warranty rights provided that:
  - a) The sold product is assembled and installed by the Guarantor or a contractor who holds the Installation Authorization Certificate (issued by the Guarantor), and the assembly and installation process is certified with the relevant entry on the last page of this Warranty Certificate;
  - b) Periodic service inspections are ordered (pursuant to a separate service contract) for the product under this Warranty and to be performed by the Guarantor or the (manufacturer's) Service Authorization Certificate holder according to this schedule:
    - Every 6 months – when the product remains in its fully closed or open position without cyclic operation;
    - Every 3 months – when the product is operated in any way different than above and in compliance with the criteria established by the Guarantor in the service contract.
2. These warranty terms and conditions apply to the product sold by the Guarantor and purchased, assembled, and installed in the Republic of Poland.
3. The service inspections specified in § 2.1 above are payable.
4. Within 14 days after each service inspection completed by the Service Authorization Certificate holder, the Warranty Rights Owner shall provide the copies of the service inspection certificates to the Guarantor:
  - a) by e-mail at [serwis@malkowski.pl](mailto:serwis@malkowski.pl), and
  - b) to the Guarantor's registered office address, or the warranty rights will be made void.
5. The warranty period begins on the date of certified post-assembly and installation acceptance of the product.
6. The rights granted under this Warranty do not include the right to claim damages for lost profits or compensation



for any damage related to the failure of the product, except for the rights granted under this Warranty.

### § 3

#### **Procedure of warranty claims and exercise of warranty rights**

1. The Warranty Rights Owner is required to report each defect discovered in the product, which shall be done in writing and in 14 days after the discovery.
2. Each warranty claim shall be submitted to the Guarantor in writing or be null and void.
3. Each warranty claim submission shall include:
  - a) a copy of the Warranty Certificate;
  - b) A detailed account of the discovered defects, its causes, and conditions in which they have emerged;
  - c) The product serial number;
  - d) Proof of completion of the periodic service inspections of the product as specified in § 2.4.
4. To ensure smooth warranty claim processing, it is recommended to attach photographic evidence of the defective product to facilitate examination.
5. The Warranty Rights Owner shall provide all conditions required for and facilitating repair of the claimed product (especially by permitting access to the product and removal from service of all equipment which can be hazardous to the personnel removing the claimed defects).
6. Failure to submit a warranty claim by the time specified in § 3.1 will release the Guarantor from the obligation of processing the warranty claim.

### § 4

#### **Warranty rights**

1. If the warranty claim made under the Warranty is reasonable, the Guarantor shall, at its own discretion, remove the defects of the product (by repairing it) or replace the product (or its affected part) with a new counterpart.
2. The title of the replaced defective products will become property of the Guarantor.
3. If defects or failures are discovered during the warranty period and prevent use of the product, the Guarantor shall act as reasonably required to remove the defects or failures in 10 business days from the date of claim.
4. If defects or failures are discovered during the warranty period and DO NOT prevent use of the product, the Guarantor shall act as reasonably required to remove the defects or failures in 20 business days from the date of claim.
5. The time limits specified in § 4.3 and § 4.4 can be extended due to reasonably important causes, especially whenever:
  - a) the parts necessary for the execution of the warranty rights are not available on the market;
  - b) it is necessary to import some or all parts from abroad to process the warranty claim;
  - c) reasons beyond any control of the Guarantor arise, of which the Warranty Rights Holder will be advised.
6. Business days shall be understood as days from Monday to Friday, excluding holidays and other statutory work-free days.
7. If, in the performance of its obligations, the Guarantor supplies the Warranty Rights Holder with an item free of defects instead of a defective item, or has made significant repairs of an item on warranty, the warranty period for the item shall run again from the date of delivery of the item free of defects or the return of the repaired item to the Warranty Rights Holder.
8. The warranty for the replaced items shall start again from the date of delivery of the item free of defects or repaired, with respect to the replaced item.
9. The replacement of parts/items shall not result in extension of the warranty period for the whole product sold.
10. The Guarantor is entitled to charge the Warranty Rights Holder with the costs of an unreasonable warranty claim (which is unreasonable if the claimed defect does not exist or the claim features a request for remedying a defect not covered by this Warranty).
11. The costs referred to in § 4.10 specifically include the costs of service travel to the product's site and the costs of removal of the defects, if any.
12. The costs of defect removal not covered by this Warranty will be evaluated according to the price list of the Guarantor.

### § 5

#### **Exclusion of warranty rights**

This Warranty does not cover:

1. any defects caused by anything not in the sold product;





2. defects caused by any tampering with the sold product by the Warranty Rights Owner or a third party, especially alterations and modifications without prior written authorisation of the Guarantor; if the sold product is tampered with, the WARRANTY AND THE DECLARATION OF PERFORMANCE ARE VOID;
3. defects caused by misuse / non-intended use of the product or failure in routine maintenance of the product, especially any use or maintenance in deviation from the manuals of the product to which this Warranty Certificate is attached;
4. defects resulting from assembly or repairs performed by personnel not authorized by the Guarantor;
5. the product installed on a site under this Warranty with failure to provide service inspections by the Guarantor or the Service Authorisation Certificate;
6. parts of the product which are naturally worn, partially or completely, according to the properties or the intended use (these include running assembly parts, electrical batteries, etc.);
7. mechanical damage of the product and the defects resulting from it;
8. defects caused by defects of the structure in which the product has been installed;
9. incorrect selection of the product to the conditions at the installation site;
10. defective operation of the installed equipment which has not been provided by the Guarantor, and resulting in negative impact on the product. Should any of the foregoing occurs, THE DECLARATION OF PERFORMANCE ISSUED FOR THE PRODUCT AND ITS WARRANTY CERTIFICATE are automatically void and null;
11. defects resulting from the external factors, especially fire, extreme weather, and fortuitous event;
12. damage caused by misuse of the product or its operation in deviation from the operating manuals, which also includes operation beyond the maximum performance limits;
13. use of non-genuine spare parts, which are parts not original to the Guarantor;
14. the product sold if this Warranty Certificate is redacted or defaced in any way;
15. the product sold if its nameplate is removed, damaged, or modified;
16. the product with its warranty seal is damaged or removed.

.....  
Date and signature of the Guarantor's Installation Authorisation Certificate Holder

.....  
Authorization no. and date of issue

